

φ25×φ25 □ZFSH-25		[メカニカルシール式] 構造断面図 CONSTRUCTION OF CENTRIFUGAL PUMP		御注文主 CUSTOMER		殿	
				用途 USED FOR			
機番 ITEM NO.	製番 MFG. NO.	吐出し量 CAPACITY m <sup>3</sup> /min	全揚程 TOTAL HEAD m	出力 OUT PUT kW	同期速度 SPEED min <sup>-1</sup>	台数 QUANTITY	

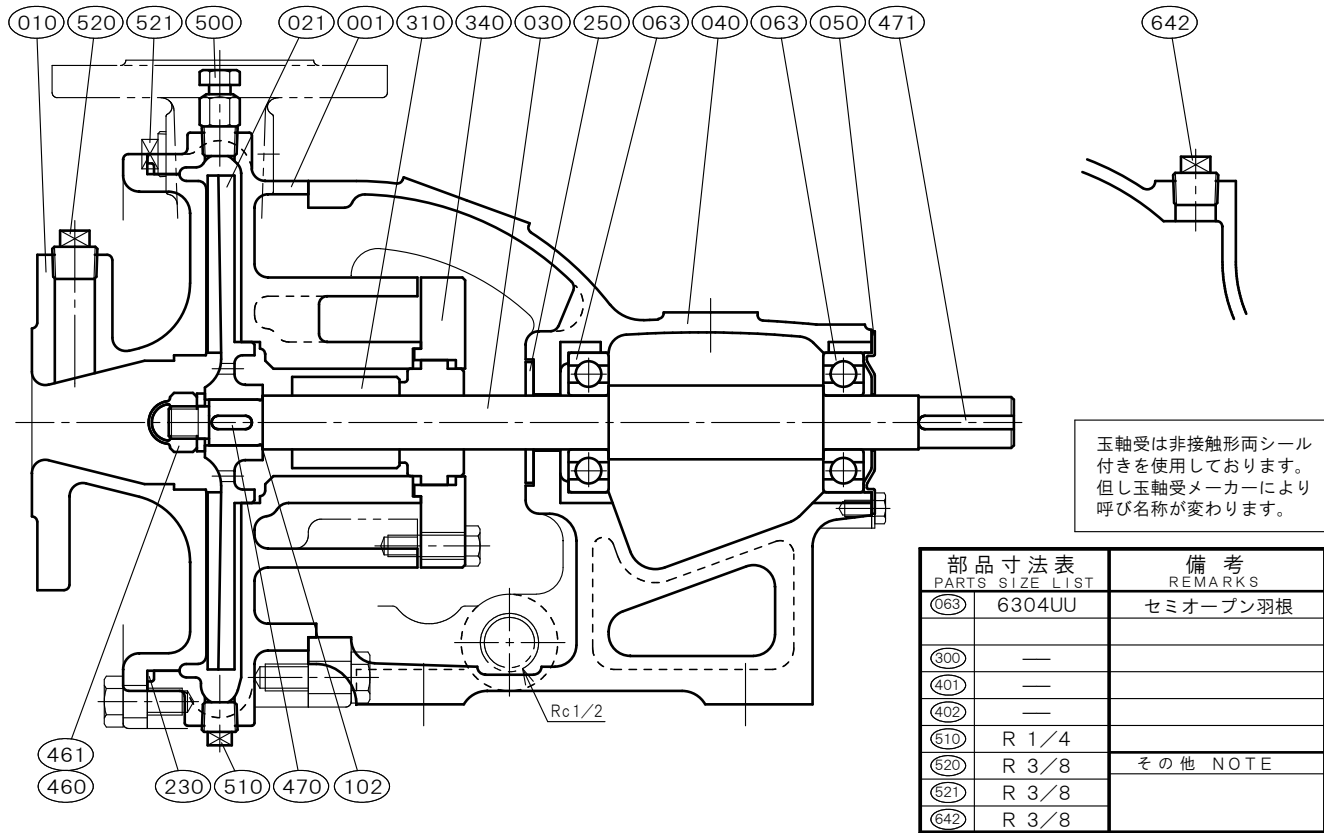

部品寸法表 PARTS SIZE LIST		備考 REMARKS	
063	6304UU		セミオープン羽根
300	—		
401	—		
402	—		
610	R 1/4		
520	R 3/8		その他 NOTE
521	R 3/8		
642	R 3/8		

NO.	部品名 NAME OF PART	材質 MATERIAL		個数 QUAN.	NO.	部品名 NAME OF PART	材質 MATERIAL		個数 QUAN.
		SCS13	SCS14				SCS13	SCS14	
001	ケーシング CASING	SCS13	SCS14	1					
010	吸込カバー SUCTION COVER	SCS13	SCS14	1					
021	羽根車 IMPELLER	SCS13	SCS14	1					
030	主軸 SHAFT	SUS304	SUS316	1					
040	軸受 METAL CASING	FC200	FC200	1					
050	軸受カバー BEARING COVER	SS400	SS400	1					
063	玉軸受 BALL BEARING	SUJ2	SUJ2	2					
102	調整リング ADJUST RING	SUS316	SUS316	n					
230	カバーパッキン COVER PACKING	FKM	FKM	1					
250	水切りつば DEFLECTOR	C R	C R	1					
310	メカニカルシール MECHANICAL SEAL	SiCvsC	SiCvsC	1set					
340	メカカバー MECHA COVER	SUS304	SUS316	1					
460	羽根車ナット IMPELLER NUT	SUS304	SUS316L	1					
461	回り止め LOCK WASHER	SUS304	SUS316L	1	標準付属品 STANDARD ACCESSORIES				
470	羽根車キー IMPELLER KEY	SUS316	SUS316	1	(600)	共通ベッド COMMON BASE	FC200	FC200	1
471	軸継手キー COUPLING KEY	S45C	S45C	1	(610)	軸継手 COUPLING	FC200	FC200	1set
500	空気抜き弁 AIR VENT VALVE	SUS304	SUS316	1	(620)	軸継手ガード COUPLING GUARD	SUS430orSS400		1
510	ドレン抜きプラグ DRAIN PLUG	SUS304	SUS316	1	(650)	基礎ボルト FOUNDATION BOLT	SS400	SS400	1set
520	真空計プラグ VACUUM GAUGE PLUG	SUS304	SUS316	1					
521	圧力計プラグ PRESSURE GAUGE PLUG	SUS304	SUS316	1					
642	呼び水プラグ PRIMING PLUG	SUS304	SUS316	1					