

φ80×φ65 □ZJS-86BX	[メカニカルシール式]		御注文主 CUSTOMER			
	構造断面図		殿			
	CONSTRUCTION OF CENTRIFUGAL PUMP		用途 USED FOR			
機番 ITEM NO.	製番 MFG. NO.	吐出し量CAPACITY	全揚程TOTAL HEAD	出力OUT PUT	同期速度 SPEED	台数QUANTITY
		m ³ /min	m	kW	min ⁻¹	

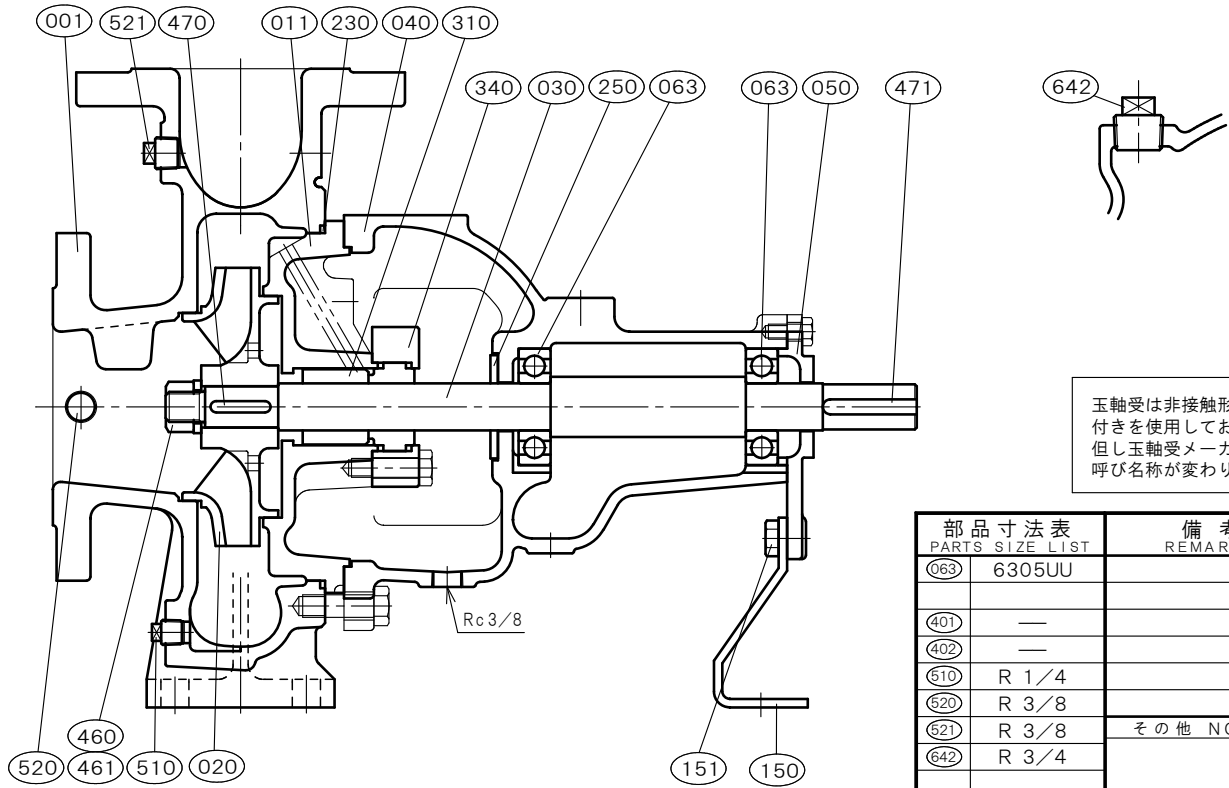

部品寸法表 PARTS SIZE LIST		備考 REMARKS
063	6305UU	
401	—	
402	—	
610	R 1/4	
620	R 3/8	
521	R 3/8	その他 NOTE
642	R 3/4	

NO.	部 品 名 NAME OF PART	材 質 MATERIAL		個数 QUAN.	NO.	部 品 名 NAME OF PART	材 質 MATERIAL		個数 QUAN.
		SCS13	SCS14				SCS13	SCS14	
001	ケーシング	CASING	SCS13 SCS14	1					
011	ケーシングカバー	CASING COVER	SCS13 SCS14	1					
020	羽根車	IMPELLER	SCS13 SCS14	1					
030	主軸	SHAFT	SUS304 SUS316	1					
040	軸受	METAL CASING	FC200 FC200	1					
050	軸受カバー	BEARING COVER	FC200 FC200	1					
063	玉軸受	BEARING	SUJ2 SUJ2	2					
150	軸受支え	BEARING SUPPORT	SS400 SS400	1					
151	軸受支えボルト	BOLT	SUS304 SUS304	2					
230	カバーパッキン	COVER PACKING	FKM FKM	1					
250	水切りつば	DEFLECTOR	C R C R	1					
310	メカニカルシール	MECHANICAL SEAL	SiCvsC SiCvsC	1set					
340	メカカバー	MECHA COVER	SUS304 SUS316	1					
460	羽根車ナット	IMPELLER NUT	SUS304 SUS316	1					
461	回り止め	LOCK WASHER	SUS304 SUS316L	1	標準付属品 STANDARD ACCESSORIES				
470	羽根車キー	IMPELLER KEY	SUS316 SUS316	1	(600)	共通ベッド	COMMON BASE	FC200 FC200	1
471	軸継手キー	COUPLING KEY	S45C S45C	1	(610)	軸継手	COUPLING	FC200 FC200	1set
510	ドレン抜きプラグ	DRAIN PLUG	SUS304 SUS316	1	(620)	軸継手ガード	COUPLING GUARD	SUS430orSS400	1
520	真空計プラグ	VACUUM GAUGE PLUG	SUS304 SUS316	1	(650)	基礎ボルト	FOUNDATION BOLT	SS400 SS400	1set
521	圧力計プラグ	PRESSURE GAUGE PLUG	SUS304 SUS316	1					
642	呼び水プラグ	PRIMING PLUG	SUS304 SUS316	1					