

φ65×φ50 □ZJS-65DH		[メカニカルシール式] 構造断面図 CONSTRUCTION OF CENTRIFUGAL PUMP		御注文主 CUSTOMER		殿	
				用途 USED FOR			
機番 ITEM NO.	製番 MFG. NO.	吐出し量CAPACITY m <sup>3</sup> /min	全揚程TOTAL HEAD m	出力OUT PUT kW	同期速度 SPEED min <sup>-1</sup>	台数 QUANTITY	

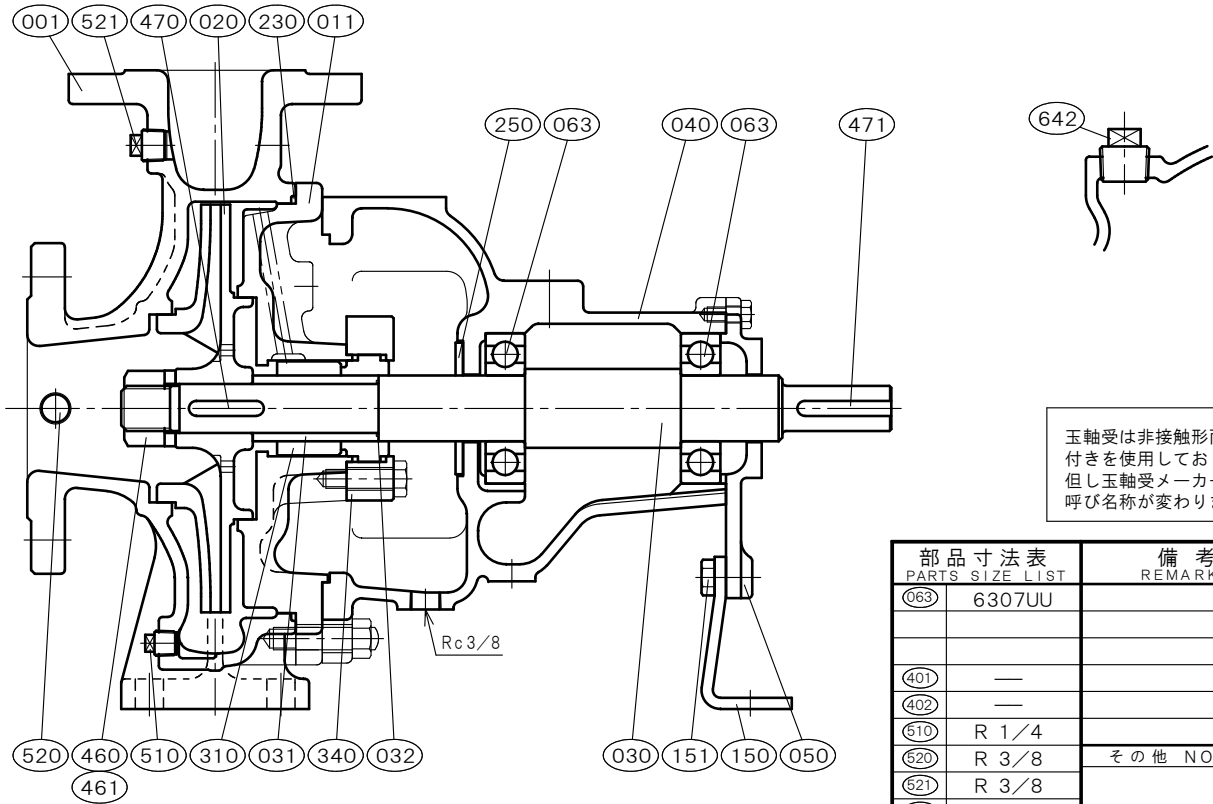

部品寸法表 PARTS SIZE LIST		備考 REMARKS	
063	6307UU		
401	—		
402	—		
610	R 1/4		
620	R 3/8		その他 NOTE
621	R 3/8		
642	R 3/4		

NO.	部品名 NAME OF PART	材質 MATERIAL		個数 QUAN.	NO.	部品名 NAME OF PART	材質 MATERIAL		個数 QUAN.
		SCS13	SCS14				SCS13	SCS14	
001	ケーシング	CASING	SCS13 SCS14	1	521	圧力計プラグ	PRESSURE GAUGE PLUG	SUS304 SUS316	1
011	ケーシングカバー	CASING COVER	SCS13 SCS14	1	642	呼び水プラグ	PRIMING PLUG	SUS304 SUS316	1
020	羽根車	IMPELLER	SCS13 SCS14	1					
030	主軸	SHAFT	SUS304 SUS316	1					
031	スリーブ	SHAFT SLEEVE	SUS304 SUS316	1					
032	スリーブパッキン	SLEEVE PACKING	PTFE PTFE	1					
040	軸受	METAL CASING	FC200 FC200	1					
050	軸受カバー	BEARING COVER	FC200 FC200	1					
063	玉軸受	BALL BEARING	SUJ2 SUJ2	2					
150	軸受支え	BEARING SUPPORT	SS400 SS400	1					
151	軸受支えボルト	BOLT	SUS304 SUS304	2					
230	カバーパッキン	COVER PACKING	FKM FKM	1					
250	水切りつば	DEFLECTOR	C R C R	1					
310	メカニカルシール	MECHANICAL SEAL	SiCvsC SiCvsC	1set	標準付属品 STANDARD ACCESSORIES				
340	メカカバー	MECHA COVER	SUS304 SUS316	1	(600)	共通ベッド	COMMON BASE	FC200 FC200	1
460	羽根車ナット	IMPELLER NUT	SUS304 SUS316	1	(610)	軸継手	COUPLING	FC200 FC200	1set
461	回り止め	LOCK WASHER	SUS304 SUS316L	1	(620)	軸継手ガード	COUPLING GUARD	SUS430orSS400	1
470	羽根車キー	IMPELLER KEY	SUS316 SUS316	1	(650)	基礎ボルト	FOUNDATION BOLT	SS400 SS400	1set
471	軸継手キー	COUPLING KEY	S45C S45C	1					
510	ドレン抜きプラグ	DRAIN PLUG	SUS304 SUS316	1					
520	真空計プラグ	VACUUM GAUGE PLUG	SUS304 SUS316	1					

西垣ポンプ製造株式会社 NISHIGAKI PUMP MFG. CO., LTD.	日付 DATE	作成 DRW.	図番 DRAWING NO.
	' 25. 4	R Y	YB3-AH1778CS