

φ80×φ80 □ZUAS-80		[メカニカルシール式] 構造断面図 CONSTRUCTION OF CENTRIFUGAL PUMP		御注文主 CUSTOMER		殿	
				用途 USED FOR			
機番 ITEM NO.	製番 MFG. NO.	吐出し量 CAPACITY m ³ /min	全揚程 TOTAL HEAD m	出力 OUT PUT kW	同期速度 SPEED min ⁻¹	台数 QUANTITY	

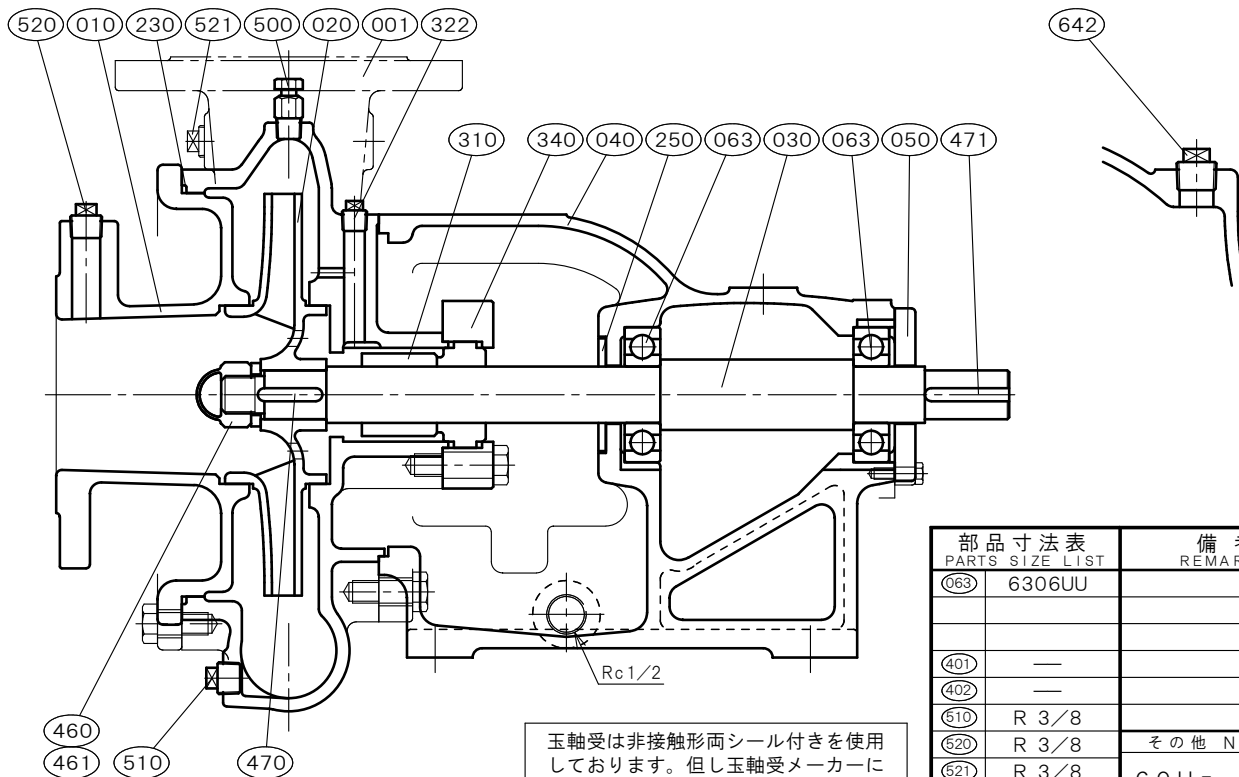

部品寸法表 PARTS SIZE LIST		備考 REMARKS
063	6306UU	
401	—	
402	—	
510	R 3/8	
520	R 3/8	その他 NOTE
521	R 3/8	60Hz-15kW
642	R 1/2	

NO.	部品名 NAME OF PART		材質 MATERIAL		個数 QUAN.	NO.	部品名 NAME OF PART		材質 MATERIAL		個数 QUAN.
	SCS13	SCS14	SCS13	SCS14			SCS13	SCS14			
001	ケーシング	CASING	SCS13	SCS14	1						
010	吸込カバー	SUCTION COVER	SCS13	SCS14	1						
020	羽根車	IMPELLER	SCS13	SCS14	1						
030	主軸	SHAFT	SUS304	SUS316	1						
040	軸受	METAL CASING	FC200	FC200	1						
050	軸受カバー	BEARING COVER	FC200	FC200	1						
063	玉軸受	BALL BEARING	SUJ2	SUJ2	2						
230	カバーパッキン	COVER PACKING	FKM	FKM	1						
250	水切りつば	DEFLECTOR	C R	C R	1						
310	メカニカルシール	MECHANICAL SEAL	CvsSiC	CvsSiC	1set						
322	封水プラグ	PLUG	SUS304	SUS316	1						
340	メカカバー	MECHA COVER	SCS13	SCS14	1						
460	羽根車ナット	IMPELLER NUT	SUS304	SUS316L	1						
461	回り止め	LOCK WASHER	SUS304	SUS316L	1	標準付属品 STANDARD ACCESSORIES					
470	羽根車キー	IMPELLER KEY	SUS316	SUS316	1	(600)	共通ベッド	COMMON BASE	FC200	FC200	1
471	軸継手キー	COUPLING KEY	S45C	S45C	1	(610)	軸継手	COUPLING	FC200	FC200	1set
500	空気抜き弁	AIR VENT VALVE	SUS304	SUS316	1	(620)	軸継手ガード	COUPLING GUARD	SUS430orSS400		1
510	ドレン抜きプラグ	DRAIN PLUG	SUS304	SUS316	1	(650)	基礎ボルト	FOUNDATION BOLT	SS400	SS400	1set
520	真空計プラグ	VACUUM GAUGE PLUG	SUS304	SUS316	1						
521	圧力計プラグ	PRESSURE GAUGE PLUG	SUS304	SUS316	1						
642	呼び水プラグ	PRIMING PLUG	SUS304	SUS316	1						

西垣ポンプ製造株式会社 NISHIGAKI PUMP MFG. CO., LTD.	日付 DATE	作成 DRW.	図番 DRAWING NO.
	' 25. 4	R Y	YB3-AA1268CS