

[グランドパッキン式] 構造断面図 CONSTRUCTION OF CENTRIFUGAL PUMP		御注文主 CUSTOMER				
		殿				
		用途 USED FOR				
機番 ITEM NO.	製番 MFG. NO.	吐出し量 CAPACITY m ³ /min	全揚程 TOTAL HEAD m	出力 OUT PUT kW	同期速度 SPEED min ⁻¹	台数 QUANTITY

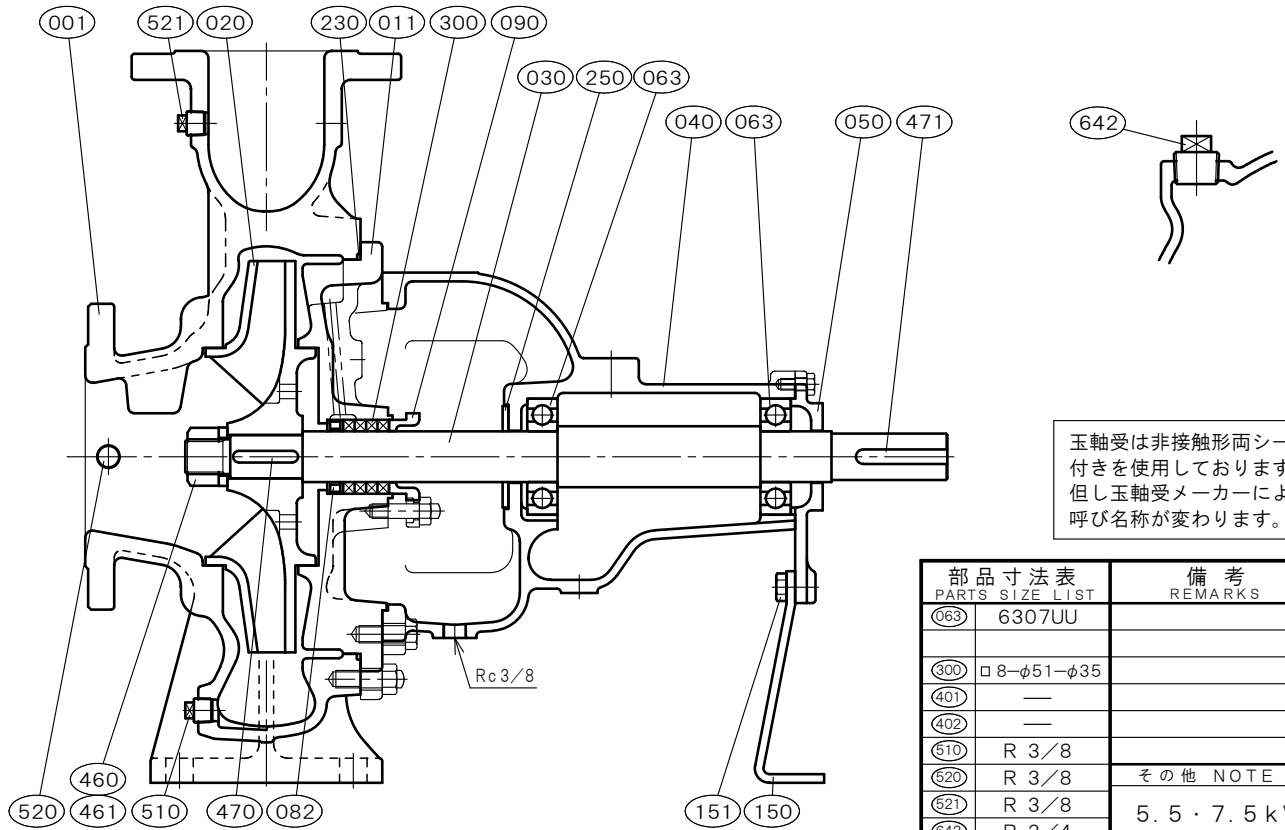

部品寸法表 PARTS SIZE LIST	備考 REMARKS	
063	6307UU	
300	□8-φ51-φ35	
401	—	
402	—	
610	R 3/8	
620	R 3/8	その他 NOTE
621	R 3/8	5.5・7.5 kW
642	R 3/4	

NO.	部品名 NAME OF PART	材質 MATERIAL		個数 QUAN.	NO.	部品名 NAME OF PART	材質 MATERIAL		個数 QUAN.
		SCS13	SCS14				SCS13	SCS14	
001	ケーシング	CASING	SCS13 SCS14	1	642	呼び水プラグ	PRIMING PLUG	SUS304 SUS316	1
011	ケーシングカバー	CASING COVER	SCS13 SCS14	1					
020	羽根車	IMPELLER	SCS13 SCS14	1					
030	主軸	SHAFT	SUS304 SUS316	1					
040	軸受	METAL CASING	FC200 FC200	1					
050	軸受カバー	BEARING COVER	FC200 FC200	1					
063	玉軸受	BALL BEARING	SUJ2 SUJ2	2					
082	封水リング	SEAL RING	SUS304 SUS316	1					
090	パッキン押さえ	GLAND	SCS14 SCS14	1					
150	軸受支え	BEARING SUPPORT	SS400 SS400	1					
151	軸受支えボルト	BOLT	SUS304 SUS304	2					
230	カバーパッキン	COVER PACKING	FKM FKM	1					
250	水切りつば	DEFLECTOR	C R C R	1					
300	グランドパッキン	GLAND PACKING	PTFE-CON PTFE-CON	4	標準付属品 STANDARD ACCESSORIES				
460	羽根車ナット	IMPELLER NUT	SUS304 SUS316	1	(600)	共通ベッド	COMMON BASE	FC200 FC200	1
461	回り止め	LOCK WASHER	SUS304 SUS316L	1	(610)	軸継手	COUPLING	FC200 FC200	1set
470	羽根車キー	IMPELLER KEY	SUS316 SUS316	1	(620)	軸継手ガード	COUPLING GUARD	SUS430orSS400	1
471	軸継手キー	COUPLING KEY	S 45C S 45C	1	(650)	基礎ボルト	FOUNDATION BOLT	SS400 SS400	1set
510	ドレン抜きプラグ	DRAIN PLUG	SUS304 SUS316	1					
520	真空計プラグ	VACUUM GAUGE PLUG	SUS304 SUS316	1					
521	圧力計プラグ	PRESSURE GAUGE PLUG	SUS304 SUS316	1					

西垣ポンプ製造株式会社 NISHIGAKI PUMP MFG. CO., LTD.	日付 DATE	作成 DRW.	図番 DRAWING NO.
	' 25. 4	R Y	YB1-AJ1477CS